



D'ANDREA®

TECHNOLOGY FOR HIGH PRECISION

2009

New Line
D'ANDREA
MHD' 110 - 140



D'ANDREA s.p.a.
Via Garbagnate 71 • 20020 Lainate (MI) Italy
Tel. +39 02 937532.1 • Fax +39 02 93753240
www.dandrea.com • info@dandrea.com



18.10.42.001.099
03/09



D'ANDREA®
TECHNOLOGY FOR HIGH PRECISION

Arbors Grundaufnahmen Acoplamientos base Mandrins Attacchi base

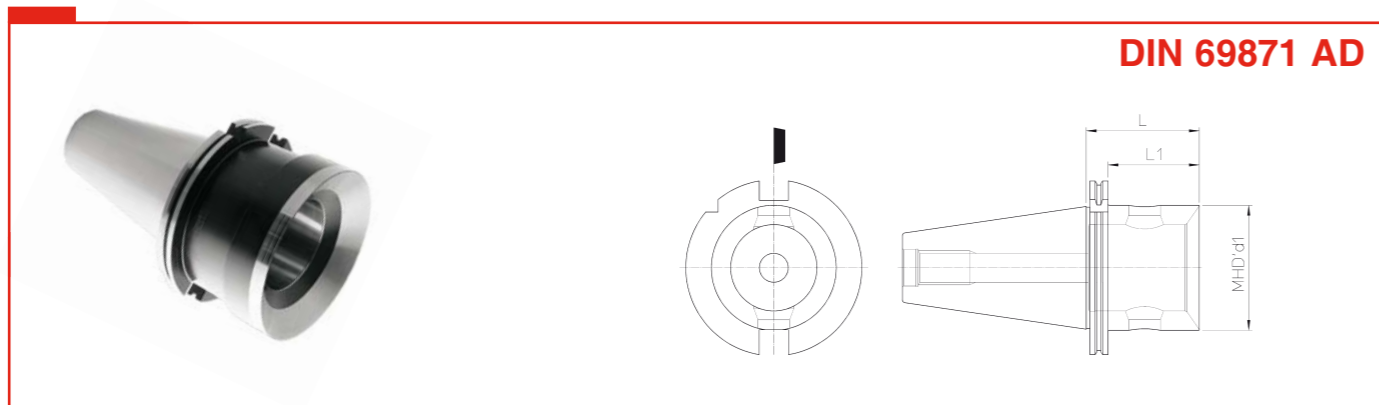

DIN 69871 AD

DIN	REF.	CODE	MHD' d ₁	L	L ₁	kg
50	DIN69871-A50 MHD'110.150	41 6 91 01 050 20	110	150	-	7.6
	DIN69871-A50 MHD'140.160	41 6 94 01 050 20	140	160	-	10
60	DIN69871-A60 MHD'110.100	41 6 91 01 060 20	110	100	81	10.5
	DIN69871-A60 MHD'110.200	41 6 91 01 060 28		200	181	18
	DIN69871-A60 MHD'140.100	41 6 94 01 060 20	140	100	81	12.8
	DIN69871-A60 MHD'140.250	41 6 94 01 060 28		250	231	30

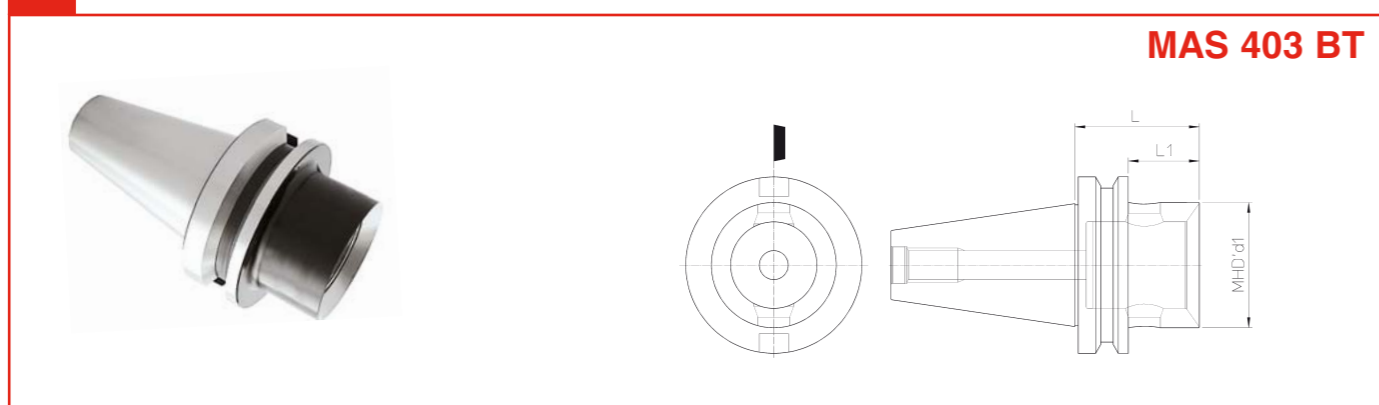

MAS 403 BT

DIN	REF.	CODE	MHD' d ₁	L	L ₁	kg
50	MAS403 BT50 MHD'110.140	41 6 91 01 050 30	110	140	-	6.8
	MAS403 BT50 MHD'140.150	41 6 94 01 050 30	140	150	-	9.2
60	MAS403 BT60 MHD'110.110	41 6 91 01 060 30	110	110	63	11.5
	MAS403 BT60 MHD'110.200	41 6 91 01 060 38		200	152	18.1
	MAS403 BT60 MHD'140.100	41 6 94 01 060 30	140	100	52	12.9
	MAS403 BT60 MHD'140.250	41 6 94 01 060 38		250	202	30.1

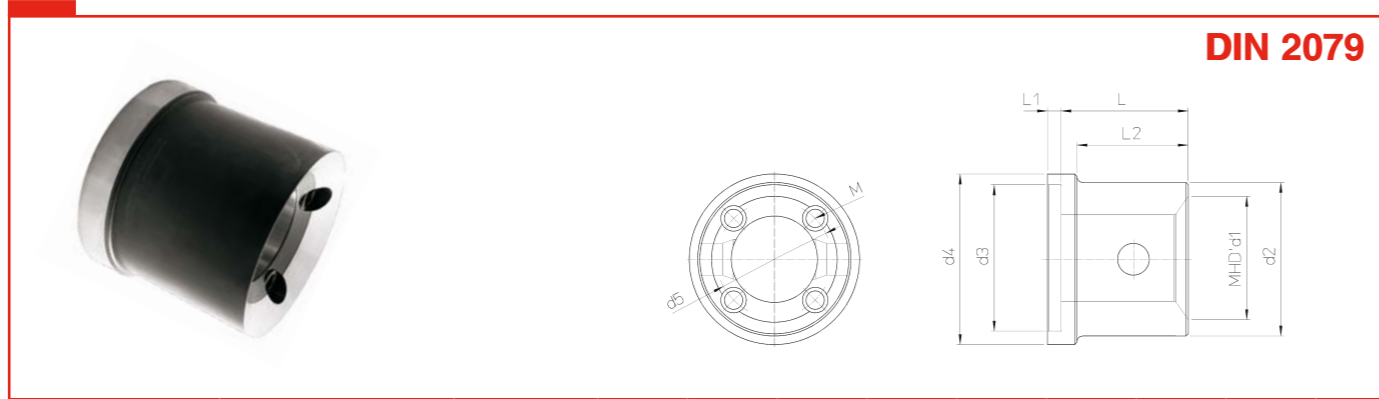

DIN 2079

REF.	CODE	MHD' d ₁	d ₂	d ₃	d ₄	d ₅	L	L ₁	L ₂	M	kg
DIN 2079-50.110	41 6 91 20 050 00	110	135	128.57	150	101.6	112	12	98	M16	8.4
DIN 2079-50.140	41 6 94 20 050 00	140	140				122		108		9.5

Extensions Verlängerungen Prolongaciones Rallonges Prolunghe

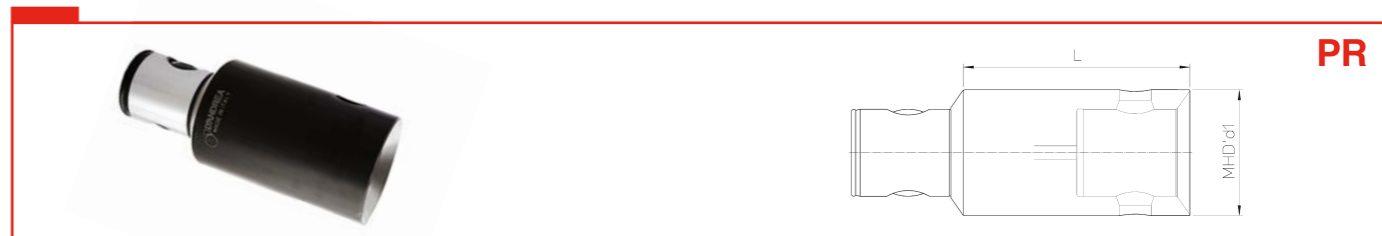

PR

REF.	CODE	MHD' d ₁	L	kg
PR 110.140	65 69 110 0140 0	110	140	13.5
PR 110.200	65 69 110 0200 0		200	14.3
PR 140.140	65 69 140 0140 0	140	140	24
PR 140.250	65 69 140 0250 0		250	28.5

Reductions Reduzierungen Reducciones Réductions Riduzioni



RD

REF.	CODE	MHD' d ₁	MHD' d ₂	L	L ₁	kg
RD 110/80.70	65 70 110 0080 0	110	80	70	52	6
RD 140/80.70	65 70 140 0080 0	140			51	7.8

Disc and facing cutter holders Scheiben- und Planfräseraufsteckdorne Adaptadores para fresas a disco y de planear Adaptateurs pour fraises à disque et à surfaçer Adattatori per fresa a disco e a spianare

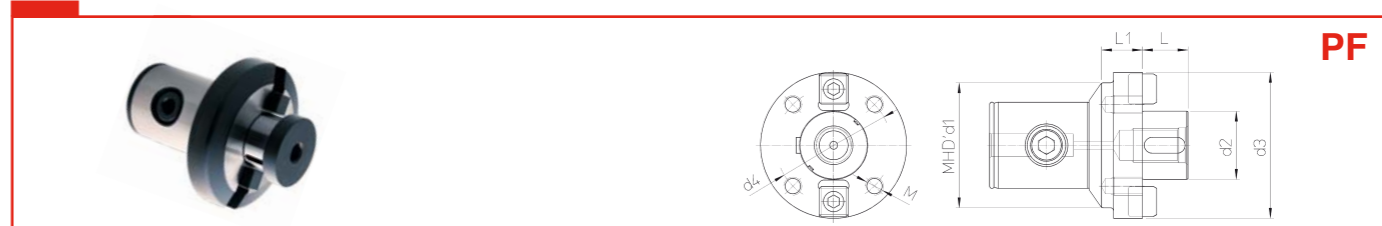

PF

REF.	CODE	MHD' d ₁	d ₂	d ₃	d ₄	M	L	L ₁	kg
PF 110/40	65 59 110 0040 0	110	40	88	66.7	M12	27	20	4.2
PF 110/60	65 59 110 0060 0		60	128.5	101.6	M16	40	36	6
PF 140/40	65 59 140 0040 0	140	40	88	66.7	M12	27	26	6.2
PF 140/60	65 59 140 0060 0		60	140	101.6	M16	40		7.8

Semifinished chuck holders Werkzeugaufnahmerohling Adaptadores semielaborados Adaptateurs semi-finis Adattatori semilavorati

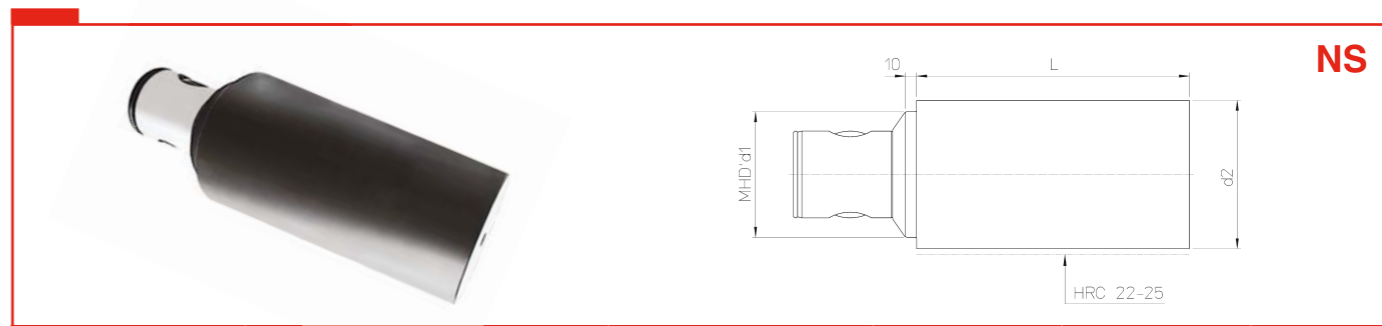

NS

REF.	CODE	MHD' d ₁	d ₂	L	kg
NS 110	65 72 110 0250 0	110	130	250	18
NS 140	65 72 140 0250 0	140	150	200	30